



Acuity Incorporated
Fremont, California
USA 94539

Acuity Series AC4065/AC4066-1P0 1 mbar Ultra-Low Pressure Sensor with Analog & Digital Outputs

NEW!

1 mbar, 0.4 inch H₂O, 100 Pa

This ultra-low pressure **1 mbar** version of the AC4065 series amplified pressure sensor is a new, extremely low-pressure amplified product featuring the Acuity **AC3070** pressure die. The sensor is calibrated either as a gauge device with the zero at 0.5 Volts and a full-scale span of 4.0 Volts or as a differential device with zero at 2.5 Volts and a span of +/- 2 Volts. The gauge part is the AC4065 while the differential part is the AC4066.

Both types have two-wire I2C digital interfaces enabling bus addressing of multiple sensors and providing not only a pressure read-out but a temperature read-out as well.

Because of the stability of the Acuity pressure sensing die, the AC4065 can use the full capability of the incorporated ASIC die while achieving at 1.0 mbar better than a 2.5% total accuracy in calibration over pressure from 0 to 70 C.

The sensor corrects the sensor signal with a multi-point calibration algorithm using a dedicated signal processor ASIC over temperature and pressure. It provides the

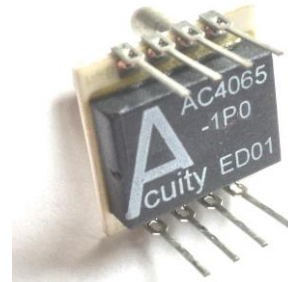

Standard Configuration of the AC4065/6-1P0

calibrated and compensated analog output which enables the part to be used in stand-alone applications.

The small foot-print of the package allows easy positioning on printed circuit boards for imbedded OEM applications such as HVAC control and low-level air flow.

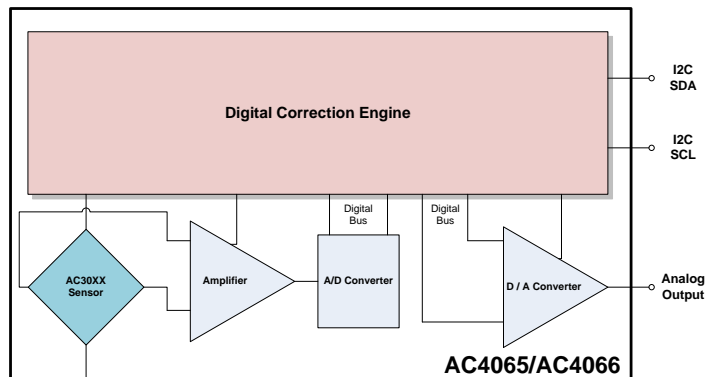

Equivalent Block Diagram of AC4065/AC4066

Dimension

NOTE:
1. Port B is used for positive differential
2. Port A is not used for gage
3. All dimensions are mm

PIN	DESCRIPTION
1	NC
2	GND
3	NC
4	SDA
5	SCL
6	NC
7	VDD
8	ANALOG OUT

I2C slave address: HEX 0x78



Acuity Incorporated
Fremont, California
USA 94539

NEW!

1 mbar, 0.4 inch H₂O, 100 Pa

Specification - V2.2a AC4065 and AC4066 -1P0		Acuity Amplified Low Pressure Sensor - 1.0 mbar				Note
Electrical Drive		Min	Nominal	Max	Unit	
Supply Voltage		4.75	5.000	5.25	Volts	1
Supply Voltage Absolute Maximum				6	Volts	
Supply Current			4	6.5	mA	
Output Drive Current		-1		1	mA	
Step Response Delay			1.5		mS	
Internal Conversion Resolution				15	bits (1 in 32768)	
Output Resolution				11	bits (1 in 2048)	1
Electrical		Min	Target	Max		
ZERO						
Zero at 25 C - AC4065		0.45	0.50	0.55	Volts	2
Zero at 25 C - AC4066		2.48	2.50	2.53	Volts	2
Zero Error at 25 C (% FS)		-1.25	±0.5	1.25	%FS	
Zero Error: 0 to 70 C (% FS)		-1.00	±0.5	1.00	%FS	4
SPAN						
Span at 25 C - AC4065		3.95	4.00	4.08	Volts	3
Span at 25 C - AC4066		1.98	2.00	2.04	Volts	3
Span Error at 25 C (% FS)		-1.25	±0.5	1.25	%FS	
Span Error: 0 to 70 C (% FS)		-1.00	±0.5	1.00	%FS	4
Linearity		-0.30	±0.1	0.30	%FS	5
STABILITY						
			Typical			
Warm-up (1 hour after turn-on)			20		mV	2
Warm-up (1 hour after turn-on)			0.5		%FS	
Position Sensitivity			10		mV/g	6
Position Sensitivity			0.25		%FS/g	6
Long-Term Drift (1 year)			30		mV	
Long-Term Drift (1 year)			0.75		%FS	
Mechanical Pressure						
Full Scale Pressure Ranges		1			mbar	
Overpressure - Burst		>100			mbar	7

Notes:

- 1 Analog output signal is ratiometric to power supply Vcc. Digital signal is not ratiometric to the power supply.
- 2 Offset voltage is the voltage output at minimum (low) pressure value. For 10mbar pressure range offset is set to 2.5V.
- 3 Full scale span is the algebraic difference between the output at full scale pressure range and offset.
- 4 Temperature effects represent maximum deviation of sensor signal (offset & span) in compensated temperature range from 0°C to 70°C relative to 25°C.
- 5 Nonlinearity is defined as the BFSL (best fit straight line) across entire pressure range.
- 6 Position sensitivity is the change in output as the sensor's orientation is changed
- 7 Over pressure is the maximum pressure which may be applied without causing damage to the sensing element.

Ordering Information:	
AC406X-PPP-T	
Where: X =	5 for Gage or 6 for Differential Pressure Range
PPP =	
I2C slave address: HEX 0x78	

Range	Full-Scale Pressure
1P0	1.0 mbar

Acuity reserves the right to make changes to its products and specifications at any time, without notice. All sales are made pursuant to Acuity's standard terms and conditions of sale. While the information in this publication has been checked, Acuity makes no representations or warranties other than as specifically set forth in the terms and conditions of sale. Acuity assumes no responsibility for the use of any information or products described herein, conveys no license under any patent or other right, and makes no representation that the information or products are free of patent infringement. Acuity does not recommend the use of any of its products in life support or other critical applications. Products are not authorized for use in such applications and customer assumes the full risk of any such use. Acuity and the Acuity logo are trademarks of Acuity, Inc. © Copyright 2018 Acuity, Incorporated.